



POWER  
VALVE-CONTROLLED

### PVC, Corzan™ CPVC, PP, PVDF

**SIZES:** 3/8" – 4"\* (DN10 to 100\*) (d16 to d110\*)

**SEALS:** EPDM or Viton

**SEATS:** PTFE (TEFLON)

**ENDS:** Socket, Threaded, Flanged,  
Metric socket or spigot

\* Body is 3" DN80, d90

### Features:

- 235 psi working pressure
- Double stem O-Rings for safety
- Integrated locking handle
- Full bore design
- Bi-directional flow
- High precision machined ball
- Dual function handle / spanner wrench
- Interchangeable colour coded ID plates on handles
- Eyelet for valve tagging
- Suitable with Praher brackets and actuator mounting kits
- Corzan™ is a registered trademark of Noveon, Inc.
- CRN No.: 0C13843.5, 0C13843.56



### Sample Specifications:

- All Praher S4 series thermoplastic ball valves sizes 3/8" – 4" shall be of true union design with a two directional blocking capability.
- Valve stems shall be of blowout-proof design with a double O-Rings seal.
- All valve handles shall be of PPGF construction with an integrated locking mechanism to lock valve in closed position.
- All handles shall be useable as a tool to remove or adjust seal carrier, and shall be fastened to valve stem with 316SS hardware.
- All O-Rings shall be EPDM or VITON and shall meet NSF/ANSI 61 criteria or be NSF/ANSI 61 approved.
- Teflon ball seats shall be cushioned with backing O-Rings that will compensate for minor ball and seat wear.
- PVC shall be NSF/ANSI 14, 61 approved or listed and meet ASTM standard D1784, cell class 12454.
- CPVC shall be NSF/ANSI 14, 61 approved or listed and meet ASTM standard D1784, cell class 23447.
- PP shall be conforming to ASTM D4101, cell class PP0210B67272 and shall be available in tan or translucent.
- PVDF shall be conforming to ASTM 3222 cell class Type II.
- All valves shall be in conformance to ISO-9393-1:2004 and ISO-9393-2:2004 test specifications for thermoplastic valves.

### Options:

- Stem extensions
- Red, Green, Blue identification plates
- Pneumatically or Electrically actuated
- Vented balls for Sodium Hypochlorite service

## PVC

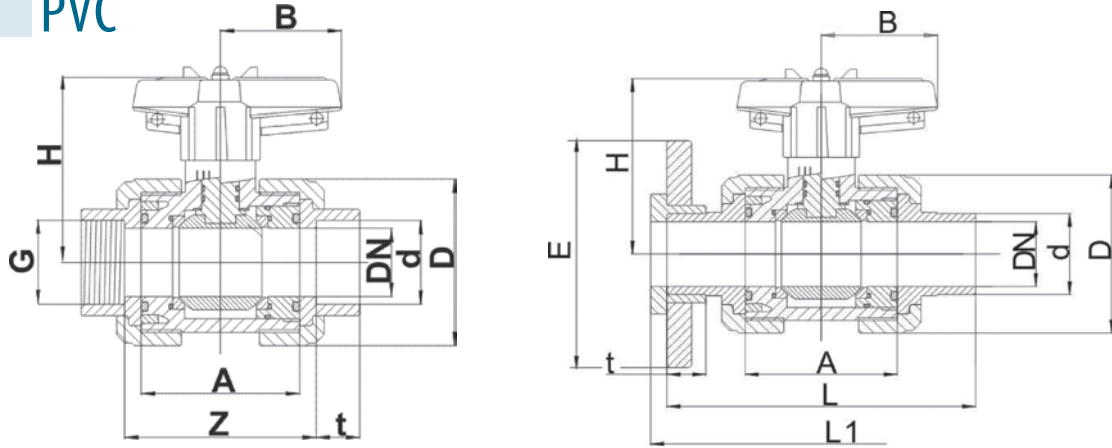

Size	DN Bore	d	Socket & threaded ends								Flanged	
			G (Thd ends)	A	B	D	H	t	Z	Z (thd ends)	E	L1
3/8"	10	16	3/8"	2.44	1.57	2.09	2.83	0.65	2.68	2.64		4.72
1/2"	15	20	1/2"	2.44	1.57	2.09	2.83	0.65	2.64	2.64	3.82	5.12
3/4"	20	25	3/4"	2.76	2.03	2.48	3.09	0.77	2.99	3.03	4.13	5.91
1"	25	32	1"	2.91	2.03	2.76	3.21	0.89	3.15	3.19	4.92	6.30
1-1/4"	32	40	1-1/4"	3.31	2.52	3.35	3.94	1.04	3.58	3.54	5.51	7.09
1-1/2"	40	50	1-1/2"	3.74	2.87	3.98	4.23	1.24	4.06	4.09	5.91	7.87
2"	50	63	2"	4.29	3.35	4.90	4.59	1.52	4.72	4.72	6.49	9.06
2-1/2"	65	75	2-1/2"	5.39	4.33	6.10	5.67	1.77	5.83	5.91	7.28	11.42
3"	80	90	3"	6.42	5.20	7.40	6.42	2.19	7.09	7.28	7.87	12.20
4"	80	110		6.42	5.20	7.40	6.42	2.52	6.81		9.02	13.78

DIMENSIONS INCHES

## CPVC

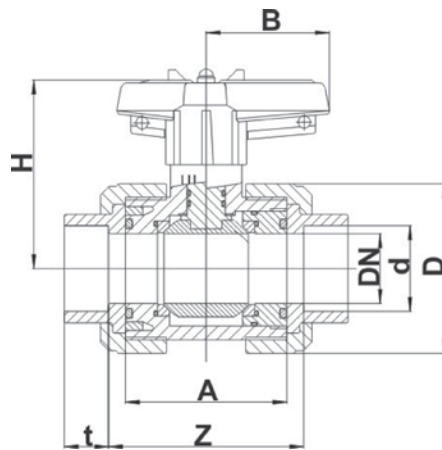

Size	DN Bore	d	Socket ends					
			A	B	D	H	t	Z
3/8"	10	16	2.44	1.57	2.09	2.83	0.65	2.68
1/2"	15	20	2.44	1.57	2.09	2.83	0.65	2.64
3/4"	20	25	2.76	2.03	2.46	3.09	0.77	2.99
1"	25	32	2.89	2.03	2.76	3.21	0.89	3.13
1-1/4"	32	40	3.29	2.52	3.33	3.94	1.04	3.52
1-1/2"	40	50	3.72	2.87	3.94	4.23	1.24	4.03
2"	50	63	4.25	3.35	4.70	4.59	1.52	4.65

DIMENSIONS INCHES

PP

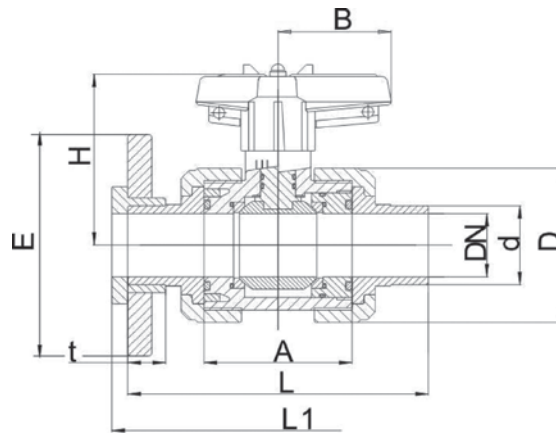
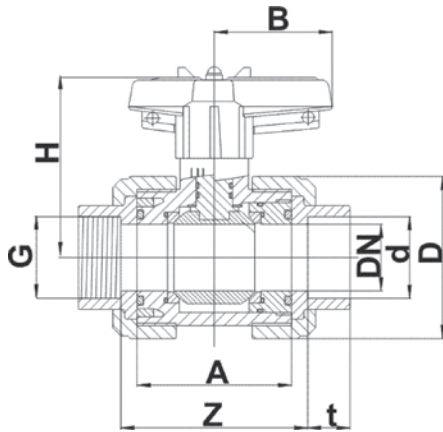

Size	DN Bore	d	Metric socket & Imperial threaded ends								Metric spigot ends		Metric flanged ends	
			G (Thd ends)	A	B	D	H	t	Z (thd ends)	Z	t	L	E	L1
3/8"	10	16	3/8"	2.44	1.57	2.09	2.81	0.65	2.64	2.8	0.51	4.49		
1/2"	15	20	1/2"	2.44	1.57	2.09	2.81	0.65	2.64	2.68	0.55	4.88	3.74	5.12
3/4"	20	25	3/4"	2.72	2.03	2.52	3.03	0.77	2.91	3.07	0.61	5.63	4.13	5.91
1"	25	32	1"	2.87	2.03	2.80	3.17	0.89	3.15	3.31	0.73	5.98	4.53	6.30
1-1/4"	32	40	1-1/4"	3.66	2.52	3.33	3.88	1.04	3.90	4.21	0.81	6.73	5.35	7.09
1-1/2"	40	50	1-1/2"	3.70	2.87	3.94	4.19	1.24	4.06	4.45	0.93	7.52	5.87	7.87
2"	50	63	2"	4.25	3.35	4.74	4.55	1.52	4.69	5.35	1.10	8.66	6.30	9.06
2-1/2"	65	75	2-1/2"	5.24	4.33	6.10	5.59	1.77	5.63	6.38	1.22	10.91		
3"	80	90	3"	6.30	5.20	7.36	6.30	2.19	7.09	8.31	1.42	11.61	7.87	12.20
4"	80	110		6.30	5.20	7.36	6.30	2.52		8.39	1.50	12.28	8.98	13.78

DIMENSIONS INCHES

PVDF

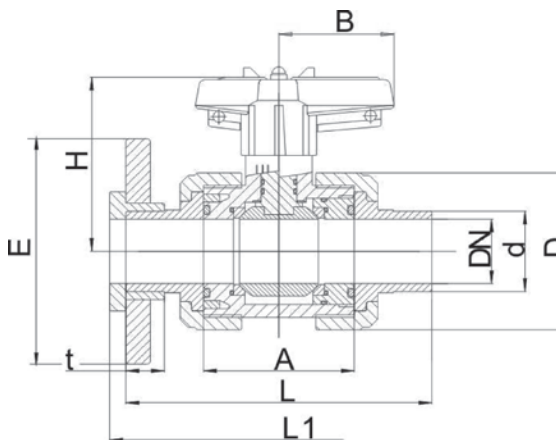
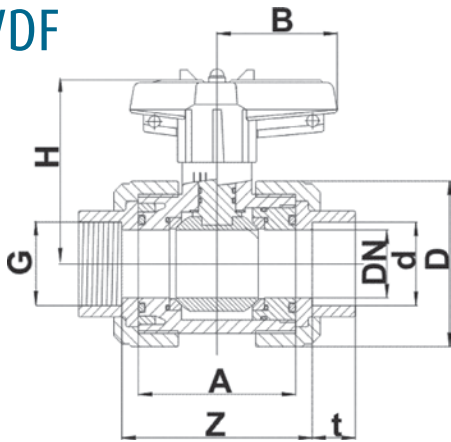

Size	DN Bore	d	Metric socket & Imperial threaded ends								Metric spigot ends		Metric flanged ends	
			G (Thd ends)	A	B	D	H	t	Z (thd ends)	Z	t	L	E	L1
3/8"	10	16	3/8"	2.44	1.57	2.07	2.81	0.57	2.64	2.80	0.51	4.49		
1/2"	15	20	1/2"	2.44	1.57	2.07	2.81	0.63	2.64	2.68	0.55	4.92	3.74	5.12
3/4"	20	25	3/4"	2.72	2.03	2.48	3.03	0.69	2.91	3.07	0.61	5.63	4.02	5.91
1"	25	32	1"	2.87	2.03	2.76	3.17	0.77	3.15	3.31	0.71	5.98	4.49	6.30
1-1/4"	32	40	1-1/4"	3.27	2.52	3.26	3.88	0.87	3.50	3.82	0.81	6.73	5.12	7.09
1-1/2"	40	50	1-1/2"	3.70	2.87	3.88	4.19	1.00	4.06	4.45	0.93	7.52	5.24	8.66
2"	50	63	2"	4.25	3.35	4.65	4.55	1.14	4.69	5.35	1.10	8.66	6.38	9.06
2-1/2"	65	75	2-1/2"	5.24	4.33	5.94	5.59	1.36	5.63	6.38	1.22	11.69	7.24	11.42
3"	80	90	3"	6.30	5.20	7.20	6.30	1.52	7.09	8.15	1.42	11.61	7.64	12.20
4"	80	110		6.30	5.20	7.20	6.30	1.63		8.39	1.50	12.60	9.02	13.78

DIMENSIONS INCHES

Weights (LBS.) Socket or Threaded		Flanged				Torque	Cv Values			
Size	PVC	CPVC	PP	PVDF	PVC	CPVC	PP	PVDF	(Inch Lbs.)	USGPM flow at 1 psi
3/8"	0.48	0.50	0.40	0.60					17.40	7
1/2"	0.48	0.50	0.40	0.60	0.9	0.9	0.7	1.1	17.40	19
3/4"	0.73	0.75	0.50	0.90	1.3	1.5	1.1	1.5	26.10	35
1"	0.90	1.00	0.60	1.10	1.8	2.0	1.5	2.2	39.15	58
1-1/4"	1.30	1.40	1.00	1.70	2.6	2.9	2.0	3.3	50.46	88
1-1/2"	2.30	2.40	1.60	2.70	3.7	4.0	2.6	4.4	67.86	129
2"	3.40	3.85	2.40	4.10	5.5	6.0	4.0	8.2	85.26	238
2-1/2"	7.10	7.50	5.00	8.60	7.3	7.7	5.3	8.8	139.20	357
3"	12.00	13.00	8.50	14.40	21.6	15.0	15.4	26.7	234.90	519
4"	12.00	21.00	8.50	14.40	21.6	23.4	15.4	26.7	234.90	519

Working Pressures (PSI)	PVC			CPVC				PP				PVDF				
	20°C 68°F	40°C 104°F	60°C 140°F	20°C 68°F	40°C 104°F	60°C 140°F	80°C 176°F	20°C 68°F	40°C 104°F	60°C 140°F	80°C 176°F	20°C 68°F	40°C 104°F	60°C 140°F	80°C 176°F	100°C 220°F
3/8" - 2"	235	145	35	235	158	107	51	145	115	58	40	235	200	150	110	85
2-1/2" - 3"	145	77	28					145	82	58	40	145	136	100	78	55
4"	87	58	23					145	82	58	40	87	84	65	50	35

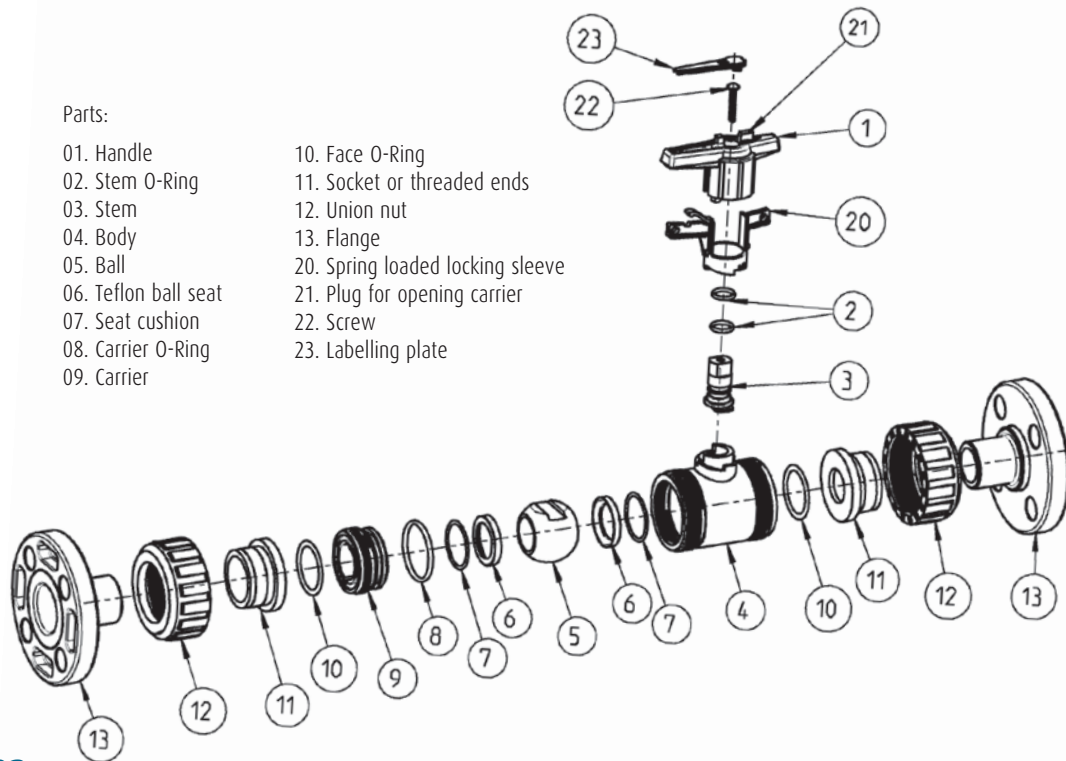

Parts:

- |                      |                                  |
|----------------------|----------------------------------|
| 01. Handle           | 10. Face O-Ring                  |
| 02. Stem O-Ring      | 11. Socket or threaded ends      |
| 03. Stem             | 12. Union nut                    |
| 04. Body             | 13. Flange                       |
| 05. Ball             | 20. Spring loaded locking sleeve |
| 06. Teflon ball seat | 21. Plug for opening carrier     |
| 07. Seat cushion     | 22. Screw                        |
| 08. Carrier O-Ring   | 23. Labelling plate              |
| 09. Carrier          |                                  |

### Caution:

- Never remove valve from pipeline under pressure.
- Always wear protective gloves and goggles.
- Watch out for trapped fluid in the valve. It is safe to close the valve before removing it from the pipeline.
- Unstable liquids such as Sodium Hypochlorite (NaClO) and Hydrogen Peroxide (H<sub>2</sub>O<sub>2</sub>) could be trapped and build gaseous pressures inside the ball. We can provide you with a vented ball to relieve the pressure build up.

**Praher Plastics Canada Ltd.**

Tel 705.725.1100  
 Fax 705.725.0444  
 101 Saunders Road  
 Barrie, Ontario, Canada L4N 9A7

[www.praherplastics.com](http://www.praherplastics.com)

Distributed by:

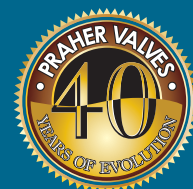

ISO 9001-2000



Proudly Manufactured in  
 North America and Austria

©Praher Plastics Canada Ltd. 2017  
 09-07-17 Rev.2